

product name: PX-02

Adjustable ignition angle DC-CDI brief product manual

1. Applicable voltage: 9~16V
2. proper temperature: -20~+40°C
3. Applicable ACG (generator) salient pole 10°~60° as shown in Figure 1
4. Applicable trigger coil polarity, as shown in Figure 2
5. Setting related:
 - A. Adjustable ignition angle (as shown in Figure <3>)
 - B. Adjustable ignition degree only works from 6500rpm
 - 0 scale ignition angle is 8°
 - 1 scale ignition angle is 10°
 - 2 scale ignition angle is 12°
 - And so on to the scale 9 ignition angle is 26°
 - C. The adjustable button of advance and retreat angle is shown in figure <5>

Precautions:

1. Do not exceed the rated voltage and temperature.
2. This product is a modified product. If the engine is damaged due to improper adjustment, please pay attention.
3. Incorrect wiring may damage the product. Please pay attention.

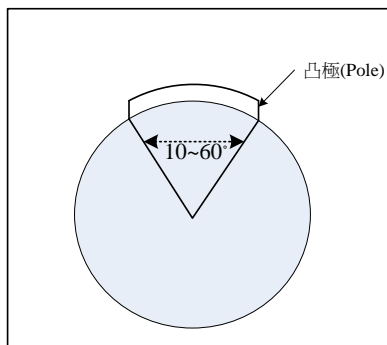

圖示一. ACG外形

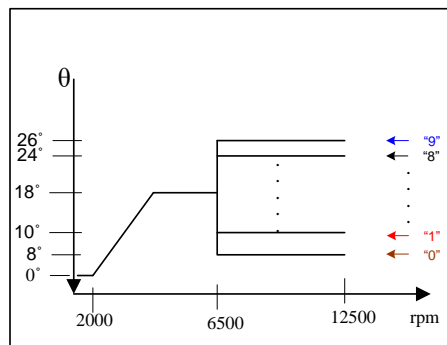

圖示三. 點火角度圖

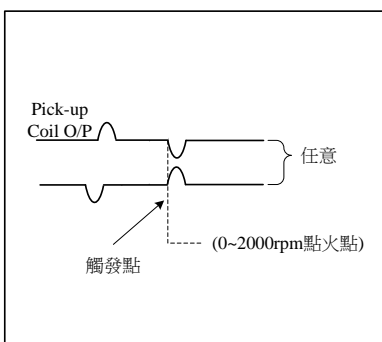

圖示二. 觸發線圈信號

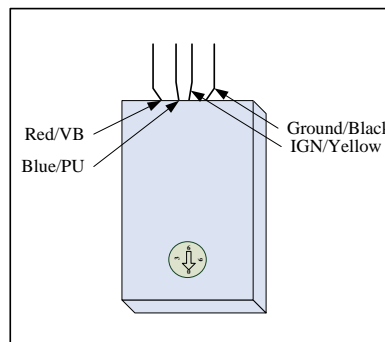

圖示五. 外型圖

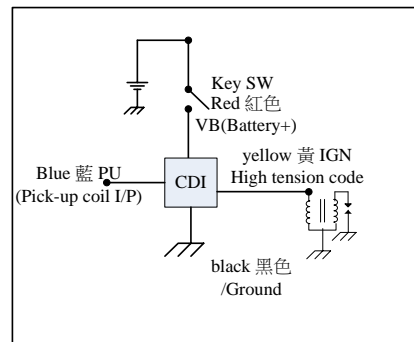

圖示四. 實車配線圖